

N G P - 3 125 R 8

Threading Grade Descriptions			
Grade	Description	Uses	Stock
200	Uncoated tough submicron - wear resistant	Non-ferrous, stainless steel alloys, aluminum & composites at slower speeds	Item specific
210	TiN coated tough submicron - wear resistant	Non-ferrous, stainless steel alloys, aluminum & composites at medium speeds	Item specific
220	AlTiN coated tough submicron - wear & heat resistant	Ductile iron, stainless steel, nickel-based & high-temp alloys at high speeds	Item specific
230	TiAlN coated tough submicron - wear & heat resistant	Non-ferrous, stainless steel, nickel-based & high-temp alloys at medium to high speed	Standard
232	TiAlN coated tough submicron - chip, wear & heat resistant	Non-ferrous, stainless steel, nickel-based & high-temp alloys at medium to high speed premium thread forms	Item specific
613	TiN coated premium substrate for threading	4140 and similar steels at slow to medium speeds - most popular threading grade	Standard
623	AlTiN coated premium substrate for threading	All steels at high speeds - maximum heat protection	Item specific
633	TiAlN coated premium substrate for threading	All steels at high speeds - medium heat protection	Item specific
Grooving Grade Descriptions			
Grade	Description	Uses	Stock
200	Uncoated tough submicron - wear resistant	Non-ferrous, stainless steel alloys composites aluminum at slower speeds	Item specific
210	TiN coated tough submicron - wear resistant	Non-ferrous, stainless steel alloys composites aluminum at medium speeds	Standard
230	TiAlN coated tough submicron - wear & heat resistant	Non-ferrous, stainless steel, nickel-based & high-temp alloys at high speeds - most popular grooving grade	Standard
612	TiN coated medium tough - long lasting, smooth cutting	4140 and similar steels medium speeds - most common steel cutting grade	Standard
632	TiAlN coated medium tough - long lasting heat resistant	All steels at high speeds - medium heat protection	Item specific

Top Notch

#2 TOP NOTCH GROOVING	DESCRIPTION	EDP	W	R	D	T	H	GAGE LENGTH	GAGE DIA.
NG2031R	27003	.031	.004	.075	.150	.219	.270	.188	
NG2031L	27004	.031	.004	.075	.150	.219	.270	.188	
NG2047R	27013	.047	.004	.090	.150	.219	.270	.188	
NG2047L	27014	.047	.004	.090	.150	.219	.270	.188	
NG2062R	27023	.062	.008	.110	.150	.219	.270	.188	
NG2062L	27024	.062	.008	.110	.150	.219	.270	.188	
NG2094R	27033	.094	.008	.110	.150	.219	.270	.188	
NG2094L	27034	.094	.008	.110	.150	.219	.270	.188	
NG2125R	27043	.125	.008	.110	.150	.219	.270	.188	
NG2125L	27044	.125	.008	.110	.150	.219	.270	.188	

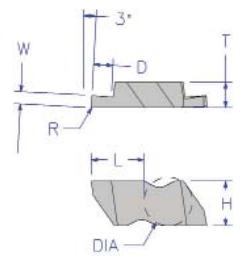

Top Notch holders and bars on pages 115-117.

#3 TOP NOTCH GROOVING	DESCRIPTION	EDP	W	R	D	T	H	GAGE LENGTH	GAGE DIA.
NG3031R	27103	.031	.004	.075	.195	.344	.405	.375	
NG3031L	27104	.031	.004	.075	.195	.344	.405	.375	
NG3047R	27113	.047	.004	.100	.195	.344	.405	.375	
NG3047L	27114	.047	.004	.100	.195	.344	.405	.375	
NG3062R	27123	.062	.008	.150	.195	.344	.405	.375	
NG3062L	27124	.062	.008	.150	.195	.344	.405	.375	
NG3072R	27133	.072	.008	.120	.195	.344	.405	.375	
NG3072L	27134	.072	.008	.120	.195	.344	.405	.375	
NG3078R	27143	.078	.008	.120	.195	.344	.405	.375	
NG3078L	27144	.078	.008	.120	.195	.344	.405	.375	
NG3088R	27153	.088	.008	.120	.195	.344	.405	.375	
NG3088L	27154	.088	.008	.120	.195	.344	.405	.375	
NG3094R	27163	.094	.008	.150	.195	.344	.405	.375	
NG3094L	27164	.094	.008	.150	.195	.344	.405	.375	
NG3097R	27173	.097	.008	.150	.195	.344	.405	.375	
NG3097L	27174	.097	.008	.150	.195	.344	.405	.375	

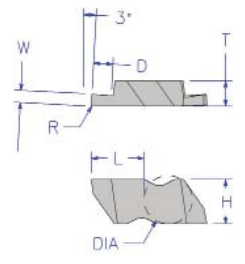

Top Notch holders and bars on pages 115-117.

Top Notch



#3 TOP NOTCH GROOVING CONTINUED	DESCRIPTION	EDP	W	R	D	T	H	GAGE LENGTH	GAGE DIA.
	NG3105R	27183	.105	.008	.150	.195	.344	.405	.375
	NG3105L	27184	.105	.008	.150	.195	.344	.405	.375
	NG3110R	27193	.110	.008	.150	.195	.344	.405	.375
	NG3110L	27194	.110	.008	.150	.195	.344	.405	.375
	NG3125R	27203	.125	.008	.190	.195	.344	.405	.375
	NG3125L	27204	.125	.008	.190	.195	.344	.405	.375
	NG3142R	27213	.142	.008	.190	.195	.344	.405	.375
	NG3142L	27214	.142	.008	.190	.195	.344	.405	.375
	NG3156R	27223	.156	.008	.190	.195	.344	.405	.375
	NG3156L	27224	.156	.008	.190	.195	.344	.405	.375
	NG3178R	27233	.178	.008	.190	.195	.344	.405	.375
	NG3178L	27234	.178	.008	.190	.195	.344	.405	.375
	NG3185R	27243	.185	.022	.190	.195	.344	.405	.375
	NG3185L	27244	.185	.022	.190	.195	.344	.405	.375
	NG3189R	27253	.189	.022	.190	.195	.344	.405	.375
	NG3189L	27254	.189	.022	.190	.195	.344	.405	.375
	NG3250R	27263	.250	.022	.190	.195	.344	.405	.375
	NG3250L	27264	.250	.022	.190	.195	.344	.405	.375

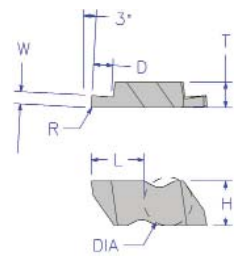

#4 TOP NOTCH GROOVING	DESCRIPTION	EDP	W	R	D	T	H	GAGE LENGTH	GAGE DIA.
	NG4125R	27313	.125	.008	.250	.255	.453	.636	.375
	NG4125L	27314	.125	.008	.250	.255	.453	.636	.375
	NG4189R	27323	.189	.022	.250	.255	.453	.636	.375
	NG4189L	27324	.189	.022	.250	.255	.453	.636	.375
	NG4250R	27343	.250	.022	.250	.255	.453	.636	.375
	NG4250L	27344	.250	.022	.250	.255	.453	.636	.375
	NG4312R	27353	.312	.032	.250	.255	.453	.636	.375
	NG4312L	27354	.312	.032	.250	.255	.453	.636	.375

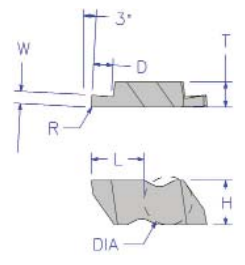

Top Notch holders and bars on pages 115-117.

Top Notch

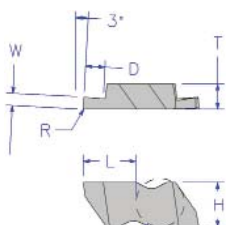
#6 TOP NOTCH GROOVING	DESCRIPTION	EDP	W	R	D	T	H	GAGE LENGTH	GAGE DIA.
	NG6281R	27403	.281	.032	.250	.383	.453	.636	.375
	NG6281L	27404	.281	.032	.250	.383	.453	.636	.375
	NG6312R	27413	.312	.032	.250	.383	.453	.636	.375
	NG6312L	27414	.312	.032	.250	.383	.453	.636	.375
	NG6375R	27423	.375	.032	.250	.383	.453	.636	.375
	NG6375L	27424	.375	.032	.250	.383	.453	.636	.375

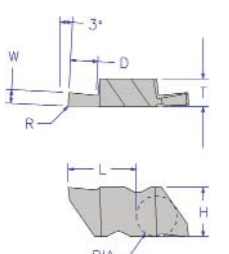
#2 TOP NOTCH GROOVING	DESCRIPTION	EDP	W	R	D	T	H	GAGE LENGTH	GAGE DIA.
5° POSITIVE RAKE 	NGP2031R	27503	.031	.004	.075	.150	.219	.270	.188
	NGP2031L	27504	.031	.004	.075	.150	.219	.270	.188
	NGP2047R	27513	.047	.004	.090	.150	.219	.270	.188
	NGP2047L	27514	.047	.004	.090	.150	.219	.270	.188
	NGP2062R	27523	.062	.008	.110	.150	.219	.270	.188
	NGP2062L	27524	.062	.008	.110	.150	.219	.270	.188
	NGP2094R	27533	.094	.008	.110	.150	.219	.270	.188
	NGP2094L	27534	.094	.008	.110	.150	.219	.270	.188
	NGP2125R	27543	.125	.008	.110	.150	.219	.270	.188
	NGP2125L	27544	.125	.008	.110	.150	.219	.270	.188

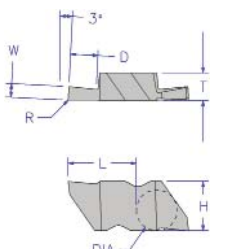
#3 TOP NOTCH GROOVING	DESCRIPTION	EDP	W	R	D	T	H	GAGE LENGTH	GAGE DIA.
5° POSITIVE RAKE 	NGP3031R	27603	.031	.004	.075	.195	.344	.405	.375
	NGP3031L	27604	.031	.004	.075	.195	.344	.405	.375
	NGP3047R	27613	.047	.004	.100	.195	.344	.405	.375
	NGP3047L	27614	.047	.004	.100	.195	.344	.405	.375
	NGP3062R	27623	.062	.008	.150	.195	.344	.405	.375
	NGP3062L	27624	.062	.008	.150	.195	.344	.405	.375
	NGP3072R	27633	.072	.008	.120	.195	.344	.405	.375
	NGP3072L	27634	.072	.008	.120	.195	.344	.405	.375

Top Notch holders and bars on pages 115-117.

Top Notch



#3 TOP NOTCH GROOVING CONTINUED	DESCRIPTION	EDP	W	R	D	T	H	GAGE LENGTH	GAGE DIA.
<p>5° POSITIVE RAKE</p>	NGP3078R	27643	.078	.008	.120	.195	.344	.405	.375
	NGP3078L	27644	.078	.008	.120	.195	.344	.405	.375
	NGP3088R	27653	.088	.008	.120	.195	.344	.405	.375
	NGP3088L	27654	.088	.008	.120	.195	.344	.405	.375
	NGP3094R	27663	.094	.008	.150	.195	.344	.405	.375
	NGP3094L	27664	.094	.008	.150	.195	.344	.405	.375
	NGP3097R	27673	.097	.008	.150	.195	.344	.405	.375
	NGP3097L	27674	.097	.008	.150	.195	.344	.405	.375
	NGP3105R	27683	.105	.008	.150	.195	.344	.405	.375
	NGP3105L	27684	.105	.008	.150	.195	.344	.405	.375
	NGP3110R	27693	.110	.008	.150	.195	.344	.405	.375
	NGP3110L	27694	.110	.008	.150	.195	.344	.405	.375
	NGP3125R	27703	.125	.008	.190	.195	.344	.405	.375
	NGP3125L	27704	.125	.008	.190	.195	.344	.405	.375
	NGP3142R	27713	.142	.008	.190	.195	.344	.405	.375
	NGP3142L	27714	.142	.008	.190	.195	.344	.405	.375
	NGP3156R	27723	.156	.008	.190	.195	.344	.405	.375
	NGP3156L	27724	.156	.008	.190	.195	.344	.405	.375
	NGP3178R	27733	.178	.008	.190	.195	.344	.405	.375
	NGP3178L	27734	.178	.008	.190	.195	.344	.405	.375
	NGP3185R	27743	.185	.022	.190	.195	.344	.405	.375
	NGP3185L	27744	.185	.022	.190	.195	.344	.405	.375
	NGP3189R	27753	.189	.022	.190	.195	.344	.405	.375
	NGP3189L	27754	.189	.022	.190	.195	.344	.405	.375
	NGP3250R	27763	.250	.022	.190	.195	.344	.405	.375
	NGP3250L	27764	.250	.022	.190	.195	.344	.405	.375

Top Notch holders and bars on pages 115-117.

Top Notch

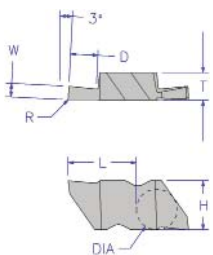
#4 TOP NOTCH GROOVING	DESCRIPTION	EDP	W	R	D	T	H	GAGE LENGTH	GAGE DIA.
5° POSITIVE RAKE 	NGP4125R	27803	.125	.008	.250	.255	.453	.636	.375
	NGP4125L	27804	.125	.008	.250	.255	.453	.636	.375
	NGP4189R	27813	.189	.022	.250	.255	.453	.636	.375
	NGP4189L	27814	.189	.022	.250	.255	.453	.636	.375
	NGP4250R	27833	.250	.022	.250	.255	.453	.636	.375
	NGP4250L	27834	.250	.022	.250	.255	.453	.636	.375
	NGP4312R	27843	.312	.032	.250	.255	.453	.636	.375
	NGP4312L	27844	.312	.032	.250	.255	.453	.636	.375

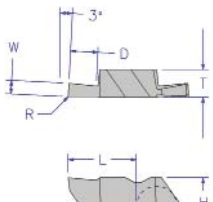
#6 TOP NOTCH GROOVING	DESCRIPTION	EDP	W	R	D	T	H	GAGE LENGTH	GAGE DIA.
5° POSITIVE RAKE 	NGP6281R	27903	.281	.032	.250	.383	.453	.636	.375
	NGP6281L	27904	.281	.032	.250	.383	.453	.636	.375
	NGP6312R	27913	.312	.032	.250	.383	.453	.636	.375
	NGP6312L	27914	.312	.032	.250	.383	.453	.636	.375
	NGP6375R	27923	.375	.032	.250	.383	.453	.636	.375
	NGP6375L	27924	.375	.032	.250	.383	.453	.636	.375

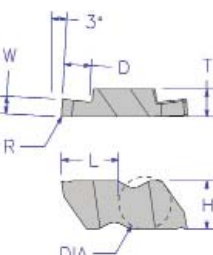
#2 TOP NOTCH GROOVING	DESCRIPTION	EDP	W	R	D	T	H	GAGE LENGTH	GAGE DIA.
K-STYLE CHIP CURLER 	NG2031RK	28003	.031	.004	.075	.150	.219	.270	.188
	NG2031LK	28004	.031	.004	.075	.150	.219	.270	.188
	NG2047RK	28013	.047	.004	.090	.150	.219	.270	.188
	NG2047LK	28014	.047	.004	.090	.150	.219	.270	.188
	NG2062RK	28023	.062	.008	.110	.150	.219	.270	.188
	NG2062LK	28024	.062	.008	.110	.150	.219	.270	.188
	NG2094RK	28033	.094	.008	.110	.150	.219	.270	.188
	NG2094LK	28034	.094	.008	.110	.150	.219	.270	.188
	NG2125RK	28043	.125	.008	.110	.150	.219	.270	.188
	NG2125LK	28044	.125	.008	.110	.150	.219	.270	.188

Top Notch holders and bars on pages 115-117.



#3 TOP NOTCH GROOVING

K-STYLE CHIP CURLER

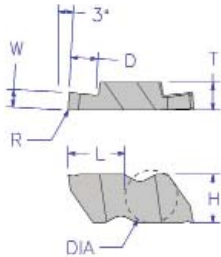

DESCRIPTION	EDP	W	R	D	T	H	GAGE LENGTH	GAGE DIA.
NG3031RK	28103	.031	.004	.075	.195	.344	.405	.375
NG3031LK	28104	.031	.004	.075	.195	.344	.405	.375
NG3047RK	28113	.047	.004	.100	.195	.344	.405	.375
NG3047LK	28114	.047	.004	.100	.195	.344	.405	.375
NG3062RK	28123	.062	.008	.150	.195	.344	.405	.375
NG3062LK	28124	.062	.008	.150	.195	.344	.405	.375
NG3072RK	28133	.072	.008	.120	.195	.344	.405	.375
NG3072LK	28134	.072	.008	.120	.195	.344	.405	.375
NG3078RK	28143	.078	.008	.120	.195	.344	.405	.375
NG3078LK	28144	.078	.008	.120	.195	.344	.405	.375
NG3088RK	28153	.088	.008	.120	.195	.344	.405	.375
NG3088LK	28154	.088	.008	.120	.195	.344	.405	.375
NG3094RK	28163	.094	.008	.150	.195	.344	.405	.375
NG3094LK	28164	.094	.008	.150	.195	.344	.405	.375
NG3097RK	28173	.097	.008	.150	.195	.344	.405	.375
NG3097LK	28174	.097	.008	.150	.195	.344	.405	.375
NG3105RK	28183	.105	.008	.150	.195	.344	.405	.375
NG3105LK	28184	.105	.008	.150	.195	.344	.405	.375
NG3110RK	28193	.110	.008	.150	.195	.344	.405	.375
NG3110LK	28194	.110	.008	.150	.195	.344	.405	.375
NG3125RK	28203	.125	.008	.190	.195	.344	.405	.375
NG3125LK	28204	.125	.008	.190	.195	.344	.405	.375
NG3142RK	28213	.142	.008	.190	.195	.344	.405	.375
NG3142LK	28214	.142	.008	.190	.195	.344	.405	.375
NG3156RK	28223	.156	.008	.190	.195	.344	.405	.375
NG3156LK	28224	.156	.008	.190	.195	.344	.405	.375
NG3178RK	28233	.178	.008	.190	.195	.344	.405	.375
NG3178LK	28234	.178	.008	.190	.195	.344	.405	.375
NG3185RK	28243	.185	.022	.190	.195	.344	.405	.375
NG3185LK	28244	.185	.022	.190	.195	.344	.405	.375
NG3189RK	28253	.189	.022	.190	.195	.344	.405	.375
NG3189LK	28254	.189	.022	.190	.195	.344	.405	.375
NG3250RK	28263	.250	.022	.190	.195	.344	.405	.375
NG3250LK	28264	.250	.022	.190	.195	.344	.405	.375

Top Notch holders and bars on pages 115-117.

Top Notch

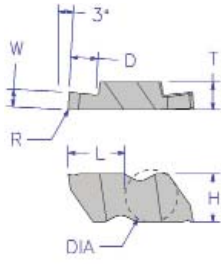
#4 TOP NOTCH GROOVING	DESCRIPTION	EDP	W	R	D	T	H	GAGE LENGTH	GAGE DIA.
K-STYLE CHIP CURLER 	NG4125RK	28303	.125	.008	.250	.255	.453	.636	.375
	NG4125LK	28304	.125	.008	.250	.255	.453	.636	.375
	NG4189RK	28313	.189	.022	.250	.255	.453	.636	.375
	NG4189LK	28314	.189	.022	.250	.255	.453	.636	.375
	NG4250RK	28333	.250	.022	.250	.255	.453	.636	.375
	NG4250LK	28334	.250	.022	.250	.255	.453	.636	.375
	NG4312RK	28343	.312	.032	.250	.255	.453	.636	.375
	NG4312LK	28344	.312	.032	.250	.255	.453	.636	.375

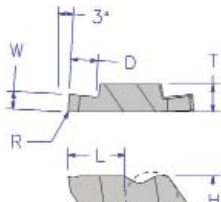
#6 TOP NOTCH GROOVING	DESCRIPTION	EDP	W	R	D	T	H	GAGE LENGTH	GAGE DIA.
K-STYLE CHIP CURLER 	NG6281RK	28403	.281	.032	.250	.383	.453	.636	.375
	NG6281LK	28404	.281	.032	.250	.383	.453	.636	.375
	NG6312RK	28413	.312	.032	.250	.383	.453	.636	.375
	NG6312LK	28414	.312	.032	.250	.383	.453	.636	.375
	NG6375RK	28423	.375	.032	.250	.383	.453	.636	.375
	NG6375LK	28424	.375	.032	.250	.383	.453	.636	.375

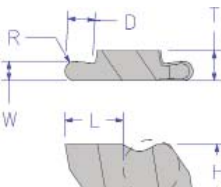
#2 TOP NOTCH GROOVING	DESCRIPTION	EDP	W	R	D	T	H	GAGE LENGTH	GAGE DIA.
FULL NOSE RADIUS 	NR2031R	28503	.062	.031	.110	.150	.219	.268	.188
	NR2031L	28504	.062	.031	.110	.150	.219	.268	.188
	NR2047R	28513	.094	.047	.110	.150	.219	.268	.188
	NR2047L	28514	.094	.047	.110	.150	.219	.268	.188
	NR2062R	28523	.125	.062	.110	.150	.219	.267	.188
	NR2062L	28524	.125	.062	.110	.150	.219	.267	.188

Top Notch holders and bars on pages 115-117.

Top Notch



#3 TOP NOTCH GROOVING	DESCRIPTION	EDP	W	R	D	T	H	GAGE LENGTH	GAGE DIA.
FULL NOSE RADIUS 	NR3031R	28603	.062	.031	.125	.195	.344	.403	.375
	NR3031L	28604	.062	.031	.125	.195	.344	.403	.375
	NR3047R	28613	.094	.047	.180	.195	.344	.403	.375
	NR3047L	28614	.094	.047	.180	.195	.344	.403	.375
	NR3062R	28623	.125	.062	.180	.195	.344	.402	.375
	NR3062L	28624	.125	.062	.180	.195	.344	.402	.375
	NR3078R	28633	.156	.078	.180	.195	.344	.401	.375
	NR3078L	28634	.156	.078	.180	.195	.344	.401	.375
	NR3094R	28643	.188	.094	.180	.195	.344	.400	.375
	NR3094L	28644	.188	.094	.180	.195	.344	.400	.375

#4 TOP NOTCH GROOVING	DESCRIPTION	EDP	W	R	D	T	H	GAGE LENGTH	GAGE DIA.
FULL NOSE RADIUS 	NR4062R	28703	.125	.062	.250	.255	.453	.633	.375
	NR4062L	28704	.125	.062	.250	.255	.453	.633	.375
	NR4094R	28713	.189	.094	.250	.255	.453	.631	.375
	NR4094L	28714	.189	.094	.250	.255	.453	.631	.375
	NR4125R	28723	.250	.125	.250	.255	.453	.629	.375
	NR4125L	28724	.250	.125	.250	.255	.453	.629	.375

#2 TOP NOTCH GROOVING	DESCRIPTION	EDP	W	R	D	T	H	GAGE LENGTH	GAGE DIA.
FULL NOSE RADIUS 5° POSITIVE RAKE 	NRP2031R	28803	.062	.031	.110	.150	.219	.268	.188
	NRP2031L	28804	.062	.031	.110	.150	.219	.268	.188
	NRP2047R	28813	.094	.047	.110	.150	.219	.268	.188
	NRP2047L	28814	.094	.047	.110	.150	.219	.268	.188
	NRP2062R	28823	.125	.062	.110	.150	.219	.267	.188
	NRP2062L	28824	.125	.062	.110	.150	.219	.267	.188

Top Notch holders and bars on pages 115-117.

Top Notch

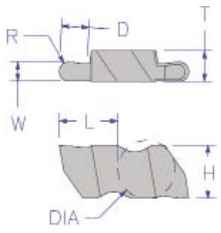
#3 TOP NOTCH GROOVING	DESCRIPTION	EDP	W	R	D	T	H	GAGE LENGTH	GAGE DIA.
FULL NOSE RADIUS 5° POSITIVE RAKE 	NRP3031R	28903	.062	.031	.125	.195	.344	.403	.375
	NRP3031L	28904	.062	.031	.125	.195	.344	.403	.375
	NRP3047R	28913	.094	.047	.180	.195	.344	.403	.375
	NRP3047L	28914	.094	.047	.180	.195	.344	.403	.375
	NRP3062R	28923	.125	.062	.180	.195	.344	.402	.375
	NRP3062L	28924	.125	.062	.180	.195	.344	.402	.375
	NRP3078R	28933	.156	.078	.180	.195	.344	.401	.375
	NRP3078L	28934	.156	.078	.180	.195	.344	.401	.375
	NRP3094R	28943	.188	.094	.180	.195	.344	.400	.375
	NRP3094L	28944	.188	.094	.180	.195	.344	.400	.375

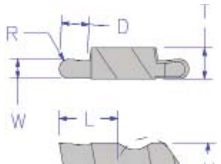
#4 TOP NOTCH GROOVING	DESCRIPTION	EDP	W	R	D	T	H	GAGE LENGTH	GAGE DIA.
FULL NOSE RADIUS 5° POSITIVE RAKE 	NRP4062R	29003	.125	.062	.250	.255	.453	.633	.375
	NRP4062L	29004	.125	.062	.250	.255	.453	.633	.375
	NRP4094R	29013	.189	.094	.250	.255	.453	.631	.375
	NRP4094L	29014	.189	.094	.250	.255	.453	.631	.375
	NRP4125R	29023	.250	.125	.250	.255	.453	.629	.375
	NRP4125L	29024	.250	.125	.250	.255	.453	.629	.375

Top Notch holders and bars on pages 115-117.

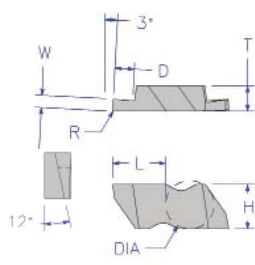
TOP NOTCH FACE GROOVING	DESCRIPTION	EDP	W	R	D	T	H	GAGE LENGTH	GAGE DIA.
	NF3031R	29103	.031	.004	.075	.195	.344	.405	.375
	NF3031L	29104	.031	.004	.075	.195	.344	.405	.375
	NF3047R	29113	.047	.004	.100	.195	.344	.405	.375
	NF3047L	29114	.047	.004	.100	.195	.344	.405	.375
	NF3062R	29123	.062	.008	.120	.195	.344	.405	.375
	NF3062L	29124	.062	.008	.120	.195	.344	.405	.375
	NF3094R	29133	.094	.008	.150	.195	.344	.405	.375
	NF3094L	29134	.094	.008	.150	.195	.344	.405	.375
	NF3125R	29143	.125	.008	.190	.195	.344	.405	.375
	NF3125L	29144	.125	.008	.190	.195	.344	.405	.375
	NF3189R	29153	.189	.022	.190	.195	.344	.405	.375
	NF3189L	29154	.189	.022	.190	.195	.344	.405	.375

Top Notch holders and bars on pages 115-117.

Top Notch



TOP NOTCH FACE GROOVING	DESCRIPTION	EDP	W	R	D	T	H	GAGE LENGTH	GAGE DIA.
	NF4125R	29203	.125	.008	.250	.255	.453	.636	.375
	NF4125L	29204	.125	.008	.250	.255	.453	.636	.375
	NF4189R	29213	.189	.022	.250	.255	.453	.636	.375
	NF4189L	29214	.189	.022	.250	.255	.453	.636	.375
	NF4250R	29223	.250	.022	.250	.255	.453	.636	.375
	NF4250L	29224	.250	.022	.250	.255	.453	.636	.375
	NF6312R	29233	.312	.032	.250	.383	.453	.636	.375
	NF6312L	29234	.312	.032	.250	.383	.453	.636	.375
	NF6375R	29243	.375	.032	.250	.383	.453	.636	.375
	NF6375L	29244	.375	.032	.250	.383	.453	.636	.375

Top Notch holders and bars on pages 115-117.

TOP NOTCH FACE GROOVING	DESCRIPTION	EDP	W	R	D	T	H	GAGE LENGTH	GAGE DIA.
<p style="text-align: center;">5° POSITIVE RAKE</p>	NFP3031R	29303	.031	.004	.075	.195	.344	.405	.375
	NFP3031L	29304	.031	.004	.075	.195	.344	.405	.375
	NFP3047R	29313	.047	.004	.100	.195	.344	.405	.375
	NFP3047L	29314	.047	.004	.100	.195	.344	.405	.375
	NFP3062R	29323	.062	.008	.120	.195	.344	.405	.375
	NFP3062L	29324	.062	.008	.120	.195	.344	.405	.375
	NFP3094R	29333	.094	.008	.150	.195	.344	.405	.375
	NFP3094L	29334	.094	.008	.150	.195	.344	.405	.375
	NFP3125R	29343	.125	.008	.190	.195	.344	.405	.375
	NFP3125L	29344	.125	.008	.190	.195	.344	.405	.375
	NFP3189R	29353	.189	.022	.190	.195	.344	.405	.375
	NFP3189L	29354	.189	.022	.190	.195	.344	.405	.375

Top Notch holders and bars on pages 115-117.

Top Notch

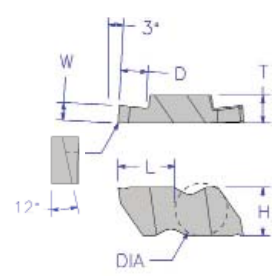
TOP NOTCH FACE GROOVING		DESCRIPTION	EDP	W	R	D	T	H	GAGE LENGTH	GAGE DIA.
K-STYLE CHIP CURLER 	NF3031RK	29403	.031	.004	.075	.195	.344	.405	.375	
	NF3031LK	29404	.031	.004	.075	.195	.344	.405	.375	
	NF3047RK	29413	.047	.004	.100	.195	.344	.405	.375	
	NF3047LK	29414	.047	.004	.100	.195	.344	.405	.375	
	NF3062RK	29423	.062	.008	.120	.195	.344	.405	.375	
	NF3062LK	29424	.062	.008	.120	.195	.344	.405	.375	
	NF3094RK	29433	.094	.008	.150	.195	.344	.405	.375	
	NF3094LK	29434	.094	.008	.150	.195	.344	.405	.375	
	NF3125RK	29443	.125	.008	.190	.195	.344	.405	.375	
	NF3125LK	29444	.125	.008	.190	.195	.344	.405	.375	
	NF3189RK	29453	.189	.022	.190	.195	.344	.405	.375	
	NF3189LK	29454	.189	.022	.190	.195	.344	.405	.375	

Top Notch holders and bars on pages 115-117.

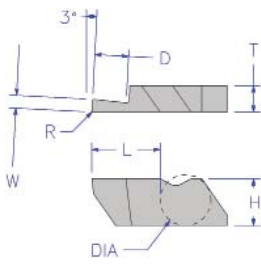
TOP NOTCH DEEP GROOVING		DESCRIPTION	EDP	W	R	D	T	H	GAGE LENGTH	GAGE DIA.
SINGLE ENDED 	NGD3062R	29503	.062	.008	.250	.195	.344	.505	.375	
	NGD3062L	29504	.062	.008	.250	.195	.344	.505	.375	
	NGD3094R	29513	.094	.008	.250	.195	.344	.505	.375	
	NGD3094L	29514	.094	.008	.250	.195	.344	.505	.375	
	NGD3125R	29523	.125	.008	.250	.195	.344	.505	.375	
	NGD3125L	29524	.125	.008	.250	.195	.344	.505	.375	
	NGD3189R	29533	.189	.022	.300	.195	.344	.505	.375	
	NGD3189L	29534	.189	.022	.300	.195	.344	.505	.375	
	NGD4125R	29543	.125	.008	.250	.255	.453	.886	.375	
	NGD4125L	29544	.125	.008	.250	.255	.453	.886	.375	
	NGD4189R	29553	.189	.022	.400	.255	.453	.886	.375	
	NGD4189L	29554	.189	.022	.400	.255	.453	.886	.375	
	NGD4250R	29563	.250	.022	.500	.255	.453	.886	.375	
	NGD4250L	29564	.250	.022	.500	.255	.453	.886	.375	

Top Notch holders and bars on pages 115-117.

Top Notch



TOP NOTCH DEEP GROOVING		DESCRIPTION	EDP	W	R	D	T	H	GAGE LENGTH	GAGE DIA.
<p>SINGLE ENDED FULL NOSE RADIUS</p>	NRD3031R	29603	.062	.031	.250	.195	.344	.505	.375	
	NRD3031L	29604	.062	.031	.250	.195	.344	.505	.375	
	NRD3062R	29613	.125	.062	.300	.195	.344	.505	.375	
	NRD3062L	29614	.125	.062	.300	.195	.344	.505	.375	
	NRD3094R	29623	.188	.094	.300	.195	.344	.505	.375	
	NRD3094L	29624	.188	.094	.300	.195	.344	.505	.375	
	NRD4094R	29633	.188	.094	.400	.255	.453	.886	.375	
	NRD4094L	29634	.188	.094	.400	.255	.453	.886	.375	
	NRD4125R	29643	.250	.125	.500	.255	.453	.886	.375	
	NRD4125L	29644	.250	.125	.500	.255	.453	.886	.375	

TOP NOTCH DEEP GROOVING		DESCRIPTION	EDP	W	R	D	T	H	GAGE LENGTH	GAGE DIA.
<p>SINGLE ENDED 5° POSITIVE RAKE</p>	NGDP3062R	29703	.062	.008	.250	.195	.344	.505	.375	
	NGDP3062L	29704	.062	.008	.250	.195	.344	.505	.375	
	NGDP3094R	29713	.094	.008	.250	.195	.344	.505	.375	
	NGDP3094L	29714	.094	.008	.250	.195	.344	.505	.375	
	NGDP3125R	29723	.125	.008	.250	.195	.344	.505	.375	
	NGDP3125L	29724	.125	.008	.250	.195	.344	.505	.375	
	NGDP3189R	29733	.189	.022	.300	.195	.344	.505	.375	
	NGDP3189L	29734	.189	.022	.300	.195	.344	.505	.375	
	NGDP4125R	29743	.125	.008	.250	.255	.453	.886	.375	
	NGDP4125L	29744	.125	.008	.250	.255	.453	.886	.375	
	NGDP4189R	29753	.189	.022	.400	.255	.453	.886	.375	
	NGDP4189L	29754	.189	.022	.400	.255	.453	.886	.375	
	NGDP4250R	29763	.250	.022	.500	.255	.453	.886	.375	
	NGDP4250L	29764	.250	.022	.500	.255	.453	.886	.375	

Top Notch holders and bars on pages 115-117.

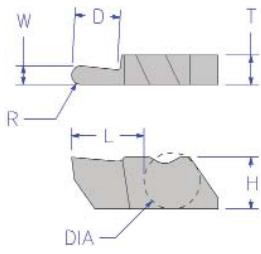
TOP NOTCH DEEP GROOVING		DESCRIPTION	EDP	W	R	D	T	H	GAGE LENGTH	GAGE DIA.
<p>SINGLE ENDED FULL NOSE RADIUS 5° POSITIVE RAKE</p> 	NRDP3031R	29803	.062	.031	.250	.195	.344	.505	.375	
	NRDP3031L	29804	.062	.031	.250	.195	.344	.505	.375	
	NRDP3062R	29813	.125	.062	.250	.195	.344	.505	.375	
	NRDP3062L	29814	.125	.062	.250	.195	.344	.505	.375	
	NRDP3094R	29823	.188	.094	.300	.195	.344	.505	.375	
	NRDP3094L	29824	.188	.094	.300	.195	.344	.505	.375	
	NRDP4094R	29833	.188	.094	.400	.255	.453	.886	.375	
	NRDP4094L	29834	.188	.094	.400	.255	.453	.886	.375	
	NRDP4125R	29843	.250	.125	.500	.255	.453	.886	.375	
	NRDP4125L	29844	.250	.125	.500	.255	.453	.886	.375	

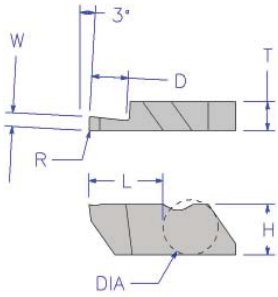
TOP NOTCH DEEP GROOVING		DESCRIPTION	EDP	W	R	D	T	H	GAGE LENGTH	GAGE DIA.
<p>SINGLE ENDED K-STYLE CHIP CURLER</p> 	NGD3062RK	32603	.062	.008	.250	.195	.344	.505	.375	
	NGD3062LK	32604	.062	.008	.250	.195	.344	.505	.375	
	NGD3094RK	32613	.094	.008	.250	.195	.344	.505	.375	
	NGD3094LK	32614	.094	.008	.250	.195	.344	.505	.375	
	NGD3125RK	32623	.125	.008	.250	.195	.344	.505	.375	
	NGD3125LK	32624	.125	.008	.250	.195	.344	.505	.375	
	NGD3189RK	32633	.189	.022	.300	.195	.344	.505	.375	
	NGD3189LK	32634	.189	.022	.300	.195	.344	.505	.375	
	NGD4125RK	32643	.125	.008	.250	.255	.453	.886	.375	
	NGD4125LK	32644	.125	.008	.250	.255	.453	.886	.375	
	NGD4189RK	32653	.189	.022	.400	.255	.453	.886	.375	
	NGD4189LK	32654	.189	.022	.400	.255	.453	.886	.375	
	NGD4250RK	32663	.250	.022	.500	.255	.453	.886	.375	
	NGD4250LK	32664	.250	.022	.500	.255	.453	.886	.375	

Top Notch holders and bars on pages 115-117.

Top Notch



TOP NOTCH DEEP FACE GROOVING		DESCRIPTION	EDP	W	R	D	T	H	GAGE LENGTH	GAGE DIA.
	NFD3062R	32703	.062	.008	.250	.195	.344	.505	.375	
	NFD3062L	32704	.062	.008	.250	.195	.344	.505	.375	
	NFD3094R	32713	.094	.008	.250	.195	.344	.505	.375	
	NFD3094L	32714	.094	.008	.250	.195	.344	.505	.375	
	NFD3125R	32723	.125	.008	.250	.195	.344	.505	.375	
	NFD3125L	32724	.125	.008	.250	.195	.344	.505	.375	
	NFD3189R	32733	.189	.022	.300	.195	.344	.505	.375	
	NFD3189L	32734	.189	.022	.300	.195	.344	.505	.375	
	NFD4125R	32743	.125	.008	.250	.255	.453	.886	.375	
	NFD4125L	32744	.125	.008	.250	.255	.453	.886	.375	
	NFD4189R	32753	.189	.022	.400	.255	.453	.886	.375	
	NFD4189L	32754	.189	.022	.400	.255	.453	.886	.375	
	NFD4250R	32763	.250	.022	.500	.255	.453	.886	.375	
	NFD4250L	32764	.250	.022	.500	.255	.453	.886	.375	

TOP NOTCH DEEP FACE GROOVING		DESCRIPTION	EDP	W	R	D	T	H	GAGE LENGTH	GAGE DIA.
<p>5° POSITIVE RAKE</p>	NFDP3062R	32803	.062	.008	.250	.195	.344	.505	.375	
	NFDP3062L	32804	.062	.008	.250	.195	.344	.505	.375	
	NFDP3094R	30813	.094	.008	.250	.195	.344	.505	.375	
	NFDP3094L	32814	.094	.008	.250	.195	.344	.505	.375	
	NFDP3125R	32823	.125	.008	.250	.195	.344	.505	.375	
	NFDP3125L	32824	.125	.008	.250	.195	.344	.505	.375	
	NFDP3189R	32833	.189	.022	.300	.195	.344	.505	.375	
	NFDP3189L	32834	.189	.022	.300	.195	.344	.505	.375	
	NFDP4125R	32843	.125	.008	.250	.255	.453	.886	.375	
	NFDP4125L	32844	.125	.008	.250	.255	.453	.886	.375	
	NFDP4189R	32853	.189	.022	.400	.255	.453	.886	.375	
	NFDP4189L	32854	.189	.022	.400	.255	.453	.886	.375	
	NFDP4250R	32863	.250	.022	.500	.255	.453	.886	.375	
	NFDP4250L	32864	.250	.022	.500	.255	.453	.886	.375	

Top Notch holders and bars on pages 115-117.

Top Notch

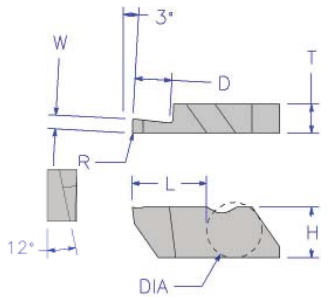
TOP NOTCH DEEP FACE GROOVING		DESCRIPTION	EDP	W	R	D	T	H	GAGE LENGTH	GAGE DIA.
K-STYLE CHIP CURLER 	NFD3062RK	32903	.062	.008	.250	.195	.344	.505	.375	
	NFD3062LK	32904	.062	.008	.250	.195	.344	.505	.375	
	NFD3094RK	32913	.094	.008	.250	.195	.344	.505	.375	
	NFD3094LK	32914	.094	.008	.250	.195	.344	.505	.375	
	NFD3125RK	32923	.125	.008	.250	.195	.344	.505	.375	
	NFD3125LK	32924	.125	.008	.250	.195	.344	.505	.375	
	NFD3189RK	32933	.189	.022	.300	.195	.344	.505	.375	
	NFD3189LK	32934	.189	.022	.300	.195	.344	.505	.375	
	NFD4125RK	32943	.125	.008	.250	.255	.453	.886	.375	
	NFD4125LK	32944	.125	.008	.250	.255	.453	.886	.375	
	NFD4189RK	32953	.189	.022	.400	.255	.453	.886	.375	
	NFD4189LK	32954	.189	.022	.400	.255	.453	.886	.375	
	NFD4250RK	32963	.250	.022	.500	.255	.453	.886	.375	
	NFD4250LK	32964	.250	.022	.500	.255	.453	.886	.375	

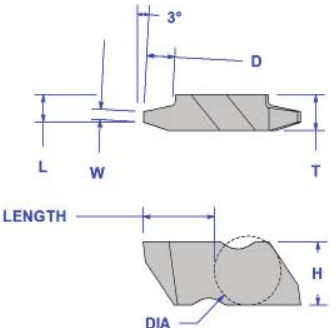
TOP NOTCH 29° ACME THREADING		DESCRIPTION	EDP	TPI	W	L	D	T	H	GAGE LENGTH	GAGE DIA.
	NA3R16	29903	16	.0206	.149	.175	.195	.344	.405	.375	
	NA3L16	29904	16	.0206	.149	.175	.195	.344	.405	.375	
	NA3R14	29913	14	.0239	.149	.175	.195	.344	.405	.375	
	NA3L14	29214	14	.0239	.149	.175	.195	.344	.405	.375	
	NA3R12	29223	12	.0283	.149	.175	.195	.344	.405	.375	
	NA3L12	29224	12	.0283	.149	.175	.195	.344	.405	.375	
	NA3R10	29933	10	.0319	.149	.175	.195	.344	.405	.375	
	NA3L10	29934	10	.0319	.149	.175	.195	.344	.405	.375	
	NA3R8	29943	8	.0411	.149	.175	.195	.344	.405	.375	
	NA3L8	29944	8	.0411	.149	.175	.195	.344	.405	.375	
	NA3R6	29953	6	.0566	.149	.175	.195	.344	.405	.375	
	NA3L6	29954	6	.0566	.149	.175	.195	.344	.405	.375	
	NA3R5	29963	5	.0689	.149	.175	.195	.344	.405	.375	
	NA3L5	29964	5	.0689	.149	.175	.195	.344	.405	.375	
	NA3R4	29973	4	.0875	.133	.200	.195	.344	.405	.375	
	NA3L4	29974	4	.0875	.133	.200	.195	.344	.405	.375	
	NA4R8	29983	8	.0411	.202	.200	.255	.453	.636	.375	
	NA4L8	29984	8	.0411	.202	.200	.255	.453	.636	.375	

Top Notch holders and bars on pages 115-117.



TOP NOTCH 29° ACME THREADING CONTINUED

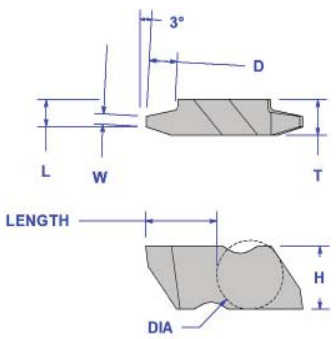

DESCRIPTION	EDP	TPI	W	L	D	T	H	GAGE LENGTH	GAGE DIA.
NA4R6	29993	6	.0566	.202	.200	.255	.453	.636	.375
NA4L6	29994	6	.0566	.202	.200	.255	.453	.636	.375
NA4R5	30003	5	.0689	.202	.200	.255	.453	.636	.375
NA4L5	30004	5	.0689	.202	.200	.255	.453	.636	.375
NA4R4	30013	4	.0875	.202	.200	.255	.453	.636	.375
NA4L4	30014	4	.0875	.202	.200	.255	.453	.636	.375
NA4R3.5	30023	3.5	.1007	.202	.200	.255	.453	.636	.375
NA4L3.5	30024	3.5	.1007	.202	.200	.255	.453	.636	.375
NA4R3	30033	3	.1184	.202	.200	.255	.453	.636	.375
NA4L3	30034	3	.1184	.202	.200	.255	.453	.636	.375
NA6R3	30043	3	.1184	.283	.300	.383	.453	.636	.375
NA6L3	30044	3	.1184	.283	.300	.383	.453	.636	.375
NA6R2.5	30053	2.5	.1431	.283	.300	.383	.453	.636	.375
NA6L2.5	30054	2.5	.1431	.283	.300	.383	.453	.636	.375
NA6R2	30063	2	.1802	.283	.300	.383	.453	.636	.375
NA6L2	30064	2	.1802	.283	.300	.383	.453	.636	.375

TOP NOTCH 29° STUB ACME THREADING

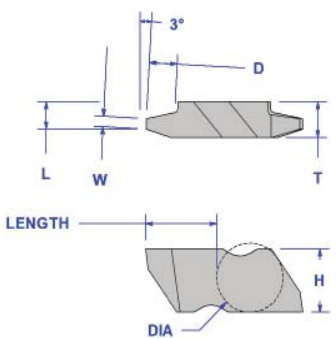

DESCRIPTION	EDP	TPI	W	L	D	T	H	GAGE LENGTH	GAGE DIA.
NAS3R16	30103	16	.0238	.149	.175	.195	.344	.405	.375
NAS3L16	30104	16	.0238	.149	.175	.195	.344	.405	.375
NAS3R14	30113	14	.0276	.149	.175	.195	.344	.405	.375
NAS3L14	30114	14	.0276	.149	.175	.195	.344	.405	.375
NAS3R12	30123	12	.0326	.149	.175	.195	.344	.405	.375
NAS3L12	30124	12	.0326	.149	.175	.195	.344	.405	.375
NAS3R10	30133	10	.0370	.149	.175	.195	.344	.405	.375
NAS3L10	30134	10	.0370	.149	.175	.195	.344	.405	.375
NAS3R8	30143	8	.0417	.149	.175	.195	.344	.405	.375
NAS3L8	30144	8	.0417	.149	.175	.195	.344	.405	.375
NAS3R6	30153	6	.0652	.149	.175	.195	.344	.405	.375
NAS3L6	30154	6	.0652	.149	.175	.195	.344	.405	.375
NAS3R5	30163	5	.0793	.149	.175	.195	.344	.405	.375
NAS3L5	30164	5	.0793	.149	.175	.195	.344	.405	.375
NAS3R4	30173	4	.1004	.133	.200	.195	.344	.405	.375
NAS3L4	30174	4	.1004	.133	.200	.195	.344	.405	.375

Top Notch holders and bars on pages 115-117.

Top Notch

**TOP NOTCH 29° STUB ACME THREADING
CONTINUED**

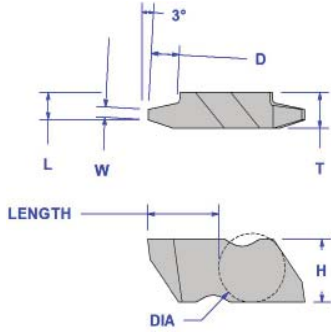

DESCRIPTION	EDP	TPI	W	L	D	T	H	GAGE LENGTH	GAGE DIA.
NAS4R8	30183	8	.0417	.202	.200	.255	.453	.636	.375
NAS4L8	30184	8	.0417	.202	.200	.255	.453	.636	.375
NAS4R6	30193	6	.0652	.202	.200	.255	.453	.636	.375
NAS4L6	30194	6	.0652	.202	.200	.255	.453	.636	.375
NAS4R5	30203	5	.0793	.202	.200	.255	.453	.636	.375
NAS4L5	30204	5	.0793	.202	.200	.255	.453	.636	.375
NAS4R4	30213	4	.1004	.202	.200	.255	.453	.636	.375
NAS4L4	30214	4	.1004	.202	.200	.255	.453	.636	.375
NAS4R3.5	30223	3.5	.1155	.202	.200	.255	.453	.636	.375
NAS4L3.5	30224	3.5	.1155	.202	.200	.255	.453	.636	.375
NAS4R3	30233	3	.1356	.202	.200	.255	.453	.636	.375
NAS4L3	30234	3	.1356	.202	.200	.255	.453	.636	.375
NAS6R3	30243	3	.1356	.283	.300	.383	.453	.636	.375
NAS6L3	30244	3	.1356	.283	.300	.383	.453	.636	.375
NAS6R2.5	30253	2.5	.1638	.283	.300	.383	.453	.636	.375
NAS6L2.5	30254	2.5	.1638	.283	.300	.383	.453	.636	.375
NAS6R2	30263	2	.2060	.283	.300	.383	.453	.636	.375
NAS6L2	30264	2	.2060	.283	.300	.383	.453	.636	.375

TOP NOTCH 60° V-THREADING

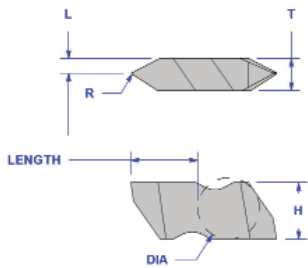

DESCRIPTION	EDP	R	L	T	H	GAGE LENGTH	GAGE DIA.
NT2R	30303	.004R	.075	.150	.219	.270	.1875
NT2L	30304	.004R	.075	.150	.219	.270	.1875
NT3R	30313	.005R	.098	.195	.344	.405	.375
NT3L	30314	.005R	.098	.195	.344	.405	.375
NT3R-8	30323	.008R	.098	.195	.344	.405	.375
NT3L-8	30324	.008R	.098	.195	.344	.405	.375
NT3R-10	30333	.010R	.098	.195	.344	.405	.375
NT3L-10	30334	.010R	.098	.195	.344	.405	.375
NT4R	30343	.007R	.128	.255	.453	.636	.375
NT4L	30344	.007R	.128	.255	.453	.636	.375

Top Notch holders and bars on pages 115-117.

Top Notch

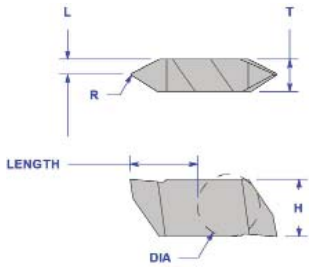

TOP NOTCH 60° V-THREADING	DESCRIPTION	EDP	R	L	T	H	GAGE LENGTH	GAGE DIA.
5° POSITIVE RAKE 	NTP2R	30403	.004R	.075	.150	.219	.270	.188
	NTP2L	30404	.004R	.075	.150	.219	.270	.188
	NTP3R	30413	.005R	.098	.195	.344	.405	.375
	NTP3L	30414	.005R	.098	.195	.344	.405	.375
	NTP3R-8	30423	.008R	.098	.195	.344	.405	.375
	NTP3L-8	30424	.008R	.098	.195	.344	.405	.375
	NTP3R-10	30433	.010R	.098	.195	.344	.405	.375
	NTP3L-10	30434	.010R	.098	.195	.344	.405	.375
	NTP4R	30443	.007R	.128	.255	.453	.636	.375
	NTP4L	30444	.007R	.128	.255	.453	.636	.375

Top Notch holders and bars on pages 115-117.

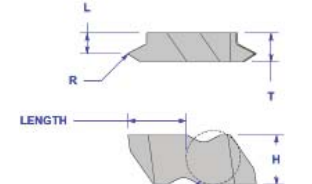
TOP NOTCH 60° V-THREADING	DESCRIPTION	EDP	R	L	T	H	GAGE LENGTH	GAGE DIA.
FINE PITCH 	NTF2R	30503	.004R	.110	.150	.219	.270	.188
	NTF2L	30504	.004R	.110	.150	.219	.270	.188
	NTF3R	30513	.004R	.141	.195	.344	.405	.375
	NTF3L	30514	.004R	.141	.195	.344	.405	.375
	NTF4R	30523	.004R	.201	.255	.453	.636	.375
	NTF4L	30524	.004R	.201	.255	.453	.636	.375

Top Notch holders and bars on pages 115-117.

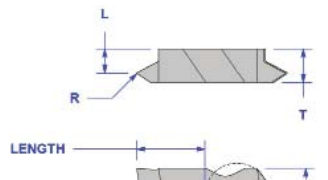
TOP NOTCH 60° V-THREADING	DESCRIPTION	EDP	R	L	T	H	GAGE LENGTH	GAGE DIA.
5° POSITIVE RAKE 	NTK2R	30603	.004R	.110	.150	.219	.270	.188
	NTK2L	30604	.004R	.110	.150	.219	.270	.188
	NTK3R	30613	.004R	.141	.195	.344	.405	.375
	NTK3L	30614	.004R	.141	.195	.344	.405	.375
	NTK4R	30623	.004R	.201	.255	.453	.636	.375
	NTK4L	30624	.004R	.201	.255	.453	.636	.375

Top Notch holders and bars on pages 115-117.

Top Notch

TOP NOTCH NON-TOPPING API THREADING

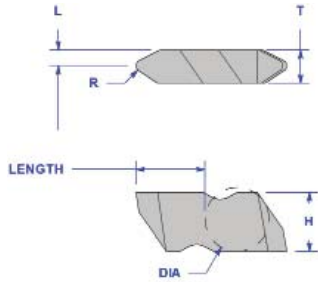

DESCRIPTION	EDP	PITCH	R	L	T	H	GAGE LENGTH	GAGE DIA.
ND3038R	30703	4	.036	.082	.195	.344	.399	.375
ND3038L	30704	4	.036	.082	.195	.344	.399	.375
ND3040R	30713	5	.018	.082	.255	.344	.399	.375
ND3040L	30714	5	.018	.082	.255	.344	.399	.375
ND4038R	30723	4	.036	.128	.255	.453	.629	.375
ND4038L	30724	4	.036	.128	.255	.453	.629	.375
ND4040R	30733	5	.018	.128	.255	.453	.629	.375
ND4040L	30734	5	.018	.128	.255	.453	.629	.375
ND4050R	30743	4	.023	.128	.255	.453	.629	.375
ND4050L	30744	4	.023	.128	.255	.453	.629	.375

Top Notch holders and bars on pages 115-117.

TOP NOTCH API ROTARY SHOULDER CONNECTION THREADING

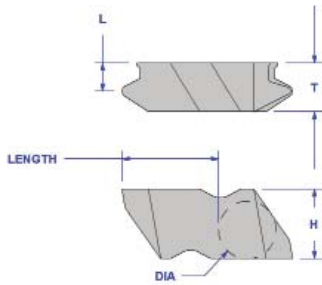

DESCRIPTION	EDP	PITCH	TPF	L	T	H	GAGE LENGTH	GAGE DIA.
NDC3-530R	30803	5	3	.147	.255	.344	.403	.375
NDC3-530L	30804	5	3	.147	.255	.344	.403	.375
NDC4-425R	30813	4	2	.183	.312	.453	.632	.375
NDC4-425L	30814	4	2	.183	.312	.453	.632	.375
NDC4-428R	30823	4	2	.183	.312	.453	.632	.375
NDC4-428L	30824	4	2	.183	.312	.453	.632	.375
NDC4-435R	30833	4	3	.183	.312	.453	.632	.375
NDC4-435L	30834	4	3	.183	.312	.453	.632	.375
NDC4-438R	30843	4	3	.183	.312	.453	.632	.375
NDC4-438L	30844	4	3	.183	.312	.453	.632	.375

Top Notch holders and bars on pages 115-117.

Top Notch

TOP NOTCH API ROUND THREADING

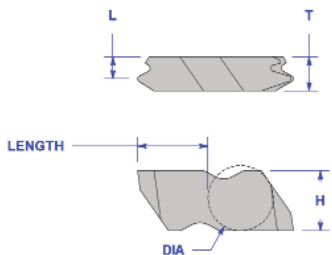

DESCRIPTION	EDP	PITCH	TPF	L	T	H	GAGE LENGTH	GAGE DIA.
NDC3-8RD75R	30853	8	3/4	.125	.195	.344	.403	.375
NDC3-8RD75L	30854	8	3/4	.125	.195	.344	.403	.375
NDC3-10RD75R	30863	10	3/4	.125	.195	.344	.403	.375
NDC3-10RD75L	30864	10	3/4	.125	.195	.344	.403	.375

Top Notch holders and bars on pages 115-117.



TOP NOTCH UNJ THREADING	DESCRIPTION	EDP	PITCH	R	L	T	H	GAGE LENGTH	GAGE DIA.
	NJ3010R16	30903	16	.010	.098	.195	.344	.400	.375
	NJ3010L16	30904	16	.010	.098	.195	.344	.400	.375
	NJ3014R12	30913	12	.013	.098	.195	.344	.400	.375
	NJ3014L12	30914	12	.013	.098	.195	.344	.400	.375
	NJ3020R8	30923	8	.020	.098	.195	.344	.400	.375
	NJ3020L8	30924	8	.020	.098	.195	.344	.400	.375

Top Notch holders and bars on pages 115-117.

TOP NOTCH UNJ THREADING	DESCRIPTION	EDP	PITCH	R	L	T	H	GAGE LENGTH	GAGE DIA.
5° POSITIVE RAKE 	NJP3010R16	31003	16	.010	.098	.195	.344	.400	.375
	NJP3010L16	31004	16	.010	.098	.195	.344	.400	.375
	NJP3014R12	31013	12	.013	.098	.195	.344	.400	.375
	NJP3014L12	31014	12	.013	.098	.195	.344	.400	.375
	NJP3020R8	31023	8	.020	.098	.195	.344	.400	.375
	NJP3020L8	31024	8	.020	.098	.195	.344	.400	.375

Top Notch holders and bars on pages 115-117.

TOP NOTCH UNJ THREADING	DESCRIPTION	EDP	PITCH	R	L	T	H	GAGE LENGTH	GAGE DIA.
FINE PITCH 	NJF3005R32	31103	32	.005	.141	.195	.344	.402	.375
	NJF3005L32	31104	32	.005	.141	.195	.344	.402	.375
	NJF3006R28	31113	28	.006	.141	.195	.344	.402	.375
	NJF3006L28	31114	28	.006	.141	.195	.344	.402	.375
	NJF3007R24	31123	24	.007	.141	.195	.344	.402	.375
	NJF3007L24	31124	24	.007	.141	.195	.344	.402	.375
	NJF3008R20	31133	20	.008	.141	.195	.344	.402	.375
	NJF3008L20	31134	20	.008	.141	.195	.344	.402	.375
	NJF3009R18	31143	18	.009	.141	.195	.344	.402	.375
	NJF3009L18	31144	18	.009	.141	.195	.344	.402	.375
	NJF3010R16	31153	16	.010	.141	.195	.344	.402	.375
	NJF3010L16	31154	16	.010	.141	.195	.344	.402	.375
	NJF3012R14	31163	14	.011	.141	.195	.344	.402	.375
	NJF3012L14	31164	14	.011	.141	.195	.344	.402	.375

Top Notch holders and bars on pages 115-117.

Top Notch

TOP NOTCH UNJ THREADING	DESCRIPTION	EDP	PITCH	R	L	T	H	GAGE LENGTH	GAGE DIA.
5° POSITIVE RAKE 	NJK3005R32	31203	32	.005	.141	.195	.344	.402	.375
	NJK3005L32	31204	32	.005	.141	.195	.344	.402	.375
	NJK3006R28	31213	28	.006	.141	.195	.344	.402	.375
	NJK3006L28	31214	28	.006	.141	.195	.344	.402	.375
	NJK3007R24	31223	24	.007	.141	.195	.344	.402	.375
	NJK3007L24	31224	24	.007	.141	.195	.344	.402	.375
	NJK3008R20	31233	20	.008	.141	.195	.344	.402	.375
	NJK3008L20	31234	20	.008	.141	.195	.344	.402	.375
	NJK3009R18	31243	18	.009	.141	.195	.344	.402	.375
	NJK3009L18	31244	18	.009	.141	.195	.344	.402	.375
	NJK3010R16	31253	16	.010	.141	.195	.344	.402	.375
	NJK3010L16	31254	16	.010	.141	.195	.344	.402	.375
	NJK3012R14	31263	14	.011	.141	.195	.344	.402	.375
	NJK3012L14	31264	14	.011	.141	.195	.344	.402	.375

Top Notch holders and bars on pages 115-117.

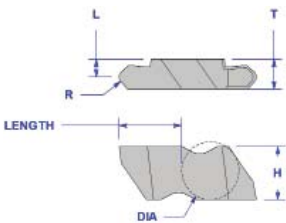
TOP NOTCH UNDERCUTTING	DESCRIPTION	EDP	W	R	D	T	H	GAGE LENGTH	GAGE DIA.
	NU3094R	31303	.094	.020	.125	.195	.344	.505	.375
	NU3094L	31304	.094	.020	.125	.195	.344	.505	.375
	NU3125R	31313	.125	.047	.188	.195	.344	.505	.375
	NU3125L	31314	.125	.047	.188	.195	.344	.505	.375
	NU3156R	31323	.156	.047	.188	.195	.344	.505	.375
	NU3156L	31324	.156	.047	.188	.195	.344	.505	.375

Top Notch holders and bars on pages 115-117.

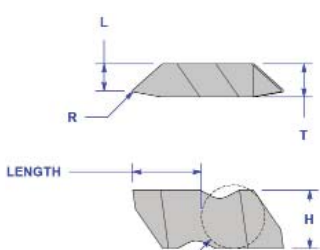
TOP NOTCH ASB 7° LEADING	DESCRIPTION	EDP	PITCH	R	L	T	H	GAGE LENGTH	GAGE DIA.
	NTB2RA	31403	16-20	.003	.126	.150	.219	.269	.188
	NTB2LA	31404	16-20	.003	.126	.150	.219	.269	.188
	NTB3RA	31413	8-12	.006	.165	.195	.344	.403	.375
	NTB3LA	31414	8-12	.006	.165	.195	.344	.403	.375
	NTB4RA	31423	4-6	.010	.206	.255	.453	.633	.375
	NTB4LA	31424	4-6	.010	.206	.255	.453	.633	.375

Top Notch holders and bars on pages 115-117.

Top Notch



TOP NOTCH ASB 45° LEADING	DESCRIPTION	EDP	PITCH	R	L	T	H	GAGE LENGTH	GAGE DIA.
	NTB2RB	31433	16-20	.003	.010	.150	.219	.269	.188
	NTB2LB	31434	16-20	.003	.010	.150	.219	.269	.188
	NTB3RB	31443	8-12	.006	.012	.195	.344	.403	.375
	NTB3LB	31444	8-12	.006	.012	.195	.344	.403	.375
	NTB4RB	31453	4-6	.010	.016	.255	.453	.633	.375
	NTB4LB	31454	4-6	.010	.016	.255	.453	.633	.375

Top Notch holders and bars on pages 115-117.

TOP NOTCH API BUTTRESS THREADING	DESCRIPTION	EDP	PITCH	TPF	L	T	H	GAGE LENGTH	GAGE DIA.
	NDC3-5B75R	31503	5	3/4	.100	.250	.344	.403	.375
	NDC3-5B75L	31504	5	3/4	.100	.250	.344	.403	.375
	NDC3-5B1R	31513	5	1	.100	.250	.344	.403	.375
	NDC3-5B1L	31514	5	1	.100	.250	.344	.403	.375
	NDC4-5B75R	31523	5	3/4	.100	.255	.453	.632	.375
	NDC4-5B75L	31524	5	3/4	.100	.255	.453	.632	.375
	NDC4-5B1R	31533	5	1	.100	.255	.453	.632	.375
	NDC4-5B1L	31534	5	1	.100	.255	.453	.632	.375

Top Notch holders and bars on pages 115-117.